

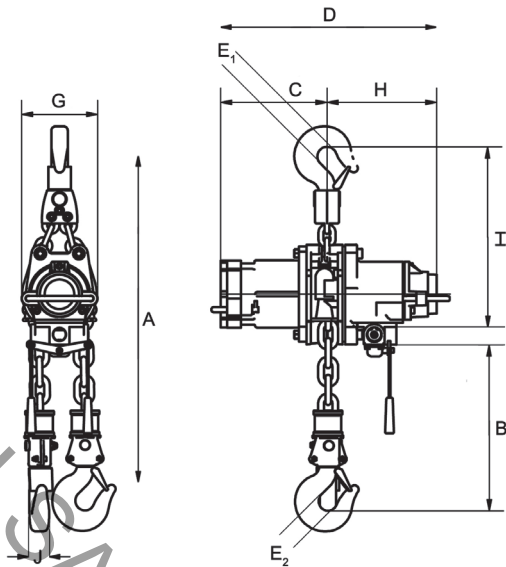

RIGGER SERIES AIR CHAIN HOIST



SPECIFICATIONS - ATS RIGGER AIR CHAIN HOIST - 1ton - 6ton

Specifications	mt	1/1	2/2	3/3	4.2/4.2	5/5	3/6
Lifting Capacity	T	1.1/1.1	2.2/2.2	3.3/3.3	4.6/4.6	5.5/5.5	3.3/6.6
Number of Fall of Chain		1	1	1	1	1	2
Motor Power Output	H.P.	1.9	1.9	2.4	3.3	3.3	3.3
	kW	1.4	1.4	1.8	2.5	2.5	2.5
Weight with Pull Cord	lbs.	97	97	137	187	271	205
Weight with Pilot Pendant	lbs.	104	104	144	194	280	213
Chain Weight Per Addt'l Ft. of Lift	lbs.	3	3	5.2	5	8	10.4
Chain Dimension	mm	7x21	9x27	13 x 36	13 x 36	16 x 45	13 x 36
Air Pressure	PSI	87	87	72-102	72-102	72-102	72-102
	bar	6	6	5-7	5-7	5-7	5-7
Air Consumption at Full Load	cfm	60-75	60-75	110	110	110	110
	m3/min	1.75	1.75	1.75	1.75	1.75	1.75
Air Hose Connection	1" BSP						
Air Hose Dimension	3/4" (19mm - 25mm)						
Lifting Speed at Full Load	ft. / min.	36	29	18.3	8.5	8.5	9.3
Lifting Speed without Load	ft. / min.	45	43	23.75	9.8	18.3	13.1
Lower Speed with Full Load	ft. / min.	36	45	25.4	11.4	24	14.3
Standard Lift	ft.	10	10	10	10	10	10
Length of Control for Standard Lift	ft.	6.5	6.5	6.5	6.5	6.5	6.5
Noise Level	84 DbA @ 1m						

DIM. - ATS RIGGER AIR CHAIN HOIST - 1ton - 6ton

Type		1 ton	2 ton	3 ton	4.2 ton	5 ton	6 ton
A min. headroom	inch	12.8	12.8	24.0	20.6	28.7	25.6
	mm	325	325	610	522	729	650
B	inch	4.7	4.7	8.9	8.9	12.6	13.1
	mm	120	120	225	225	320	333
C	inch	8.0	8.0	9.2	9.2	10.5	9.2
	mm	202	202	234	234	267	234
D	inch	15.0	15.0	18.9	18.9	20.5	18.9
	mm	382	382	480	480	521	480
E1	inch	1.3	1.3	1.6	1.6	1.7	1.6
	mm	32	32	40	40	42	40
E2	inch	1.3	1.3	1.6	1.6	1.7	1.6
	mm	32	32	40	40	42	40
G maximum width	inch	5.7	5.7	9.4	9.4	13.4	9.4
	mm	146	146	240	240	340	240
H	inch	7.1	7.1	9.7	9.7	10.0	9.7
	mm	180	180	246	246	254	246
I	inch	8.3	8.3	11.8	11.8	18.9	16.7
	mm	211	211	299	299	480	423
J (hook Width)	inch	0.9	0.9	1.8	1.8	2.1	1.9
	mm	23	23	45	45	53	48

* Chain containers will increase headroom

