

# OPERATOR'S MANUAL

## LEVER HOIST 0.75 TON THROUGH 9 TON

**These Lever Hoists  
meet or exceed  
the following  
standards:**

**CE  
AS1418.2  
ANSI B30.21  
ANSI B30.16**

**With  
Overload  
Protection**



P.O. Box 845, Winona, MN 55987  
Phone (800) 749-1064  
(507) 474-6250  
Tech Support (507) 457-3346  
Fax (507) 452-5217  
sales@ozliftingproducts.com  
www.ozliftingproducts.com

# Product Features and Benefits

**Overload Protection** - This is standard on all hoists and is factory set. The overload is integral with the hoist and prevents the operator from overloading the hoist. When activated, the overload will not allow hoist operation. When the overload is activated, lower the load, if lifting, or release the load, if pulling. Then select a larger capacity hoist, or consult a lifting specialist for another means of operation.

**Free Wheel Feature** - When not under load, the operator can disengage the gearing by positioning the selection switch to the center position. This allows for a quick adjustment of chain for faster operation.

**Fully Machined Lift Wheel** - This feature perfectly accepts the chain allowing for a smooth long lasting operation. (not available in all sizes)

**Electro Zinc Plated Hand & Load Chain** - Provides a durable finish.

**Pull Handle / Safety Chain Stop** - When not under load, this feature allows for quick disengagement of gearing which allows for fast movement of the load hook. The safety chain stop is designed and load tested to hold the load in the event that the entire load chain is transmitted through the hoist.

**360 Degree Handle Rotation** - This allows the operator to work in confined spaces.

**Fully Enclosed Lift Wheel** - This maintains smooth operation while distributing the load over more links of chain. It also helps keep debris from contaminating the lift wheel and self cleans the chain as it enters the wheel.

**Steel Handle with Rubber Grip** - This handle provides a non slip, sure grip, surface.

**Cast Steel Hand Wheel** - Rotates to allow positive load chain positioning.

**Lower Block** - Included with multistrand hoists.

**Minimal Load Lifting Effort** - These hoists require 20% - 30% less effort than the competition. Lift heavy loads with ease. Ideal for frequent lifting/pulling applications.

**Fully Enclosed Gearing** - This protects the gears from contamination and debris.

**All Steel Construction** - These hoists are strong, durable and rugged, providing a long and dependable service life.

**Forged Alloy Steel Hooks Cast Steel Safety Latches** - Each heavy duty cast steel safety latches has a bolt and lock nut connection rather than roller pins used by most competitors. This feature facilitates changing latches in the field.

**Weather Proof Load Holding Brake** - Hoists have a protected Weston Brake which holds the load during the entire operation. The hoists are also equipped with a unique twin pawl design.

**All Gears and Shafts Run on Roller Bearings and Sintered Bushes** - This feature provides smooth controlled operation as well as maintenance free lubrication.

**Stainless Steel Riveted ID Tags** - These tags will not rust and will maintain clear distinct information for easy identification.

**Safety Yellow Powder Coating** - This process provides a long lasting finish in hostile environments.

# Table of Contents

<b>Pg.2</b>	<b>Product Features and Benefits</b>
<b>Pg.3</b>	<b>Table of Contents</b>
<b>Pg.4</b>	<b>Warranty/Warranty Policy</b>
<b>Pg.5</b>	<b>Important Information and Precautions</b>
<b>Pg.6</b>	<b>Important Information and Precautions</b>
<b>Pg.7</b>	<b>Technical Information</b>
<b>Pg.8</b>	<b>Pre-Installation</b>
<b>Pg.9</b>	<b>Operation</b>
<b>Pg.10</b>	<b>Operation</b>
<b>Pg.11</b>	<b>Inspection</b>
<b>Pg.12</b>	<b>Inspection</b>
<b>Pg.13</b>	<b>Inspection</b>
<b>Pg.14</b>	<b>Inspection</b>
<b>Pg.15</b>	<b>Inspection</b>
<b>Pg.16</b>	<b>Maintenance</b>
<b>Pg.17</b>	<b>Parts List</b>
<b>Pg.18</b>	<b>Parts List</b>
<b>Pg.19</b>	<b>Service Notes</b>



**HOW TO...  
VIDEOS**

**Check out our How to Videos at  
[www.ozliftingproducts.com](http://www.ozliftingproducts.com)**

# Warranty

All OZ Lifting Products LLC. are guaranteed to be free of defects in materials and workmanship for five years from date of shipment.

This does not apply to any product showing signs of misuse, overloading, alteration, improper maintenance, or negligence. Normal wear and tear of moving parts is excluded from this warranty.

If any one of our products fails during the first five years of operating due to defective materials or workmanship it will be repaired or replaced at the discretion of OZ Lifting Products. The product will then be returned to the customer free of charge. If no defect is found the customer will be responsible for return shipping costs.

Upon repair the product will be covered by the warranty for the remainder of the original warranty. OZ lifting will not be held liable for injuries to persons or property, death, incidental, consequential, or contingent damages whether negligent or deliberate arising from the use of the product. It is the sole responsibility of the owner to install and operate the product properly and safely.

This is OZ Lifting Product's only written warranty. This warranty is in lieu of all other warranties implied by law such as merchantability and fitness.

## Warranty Policy

Any product for which there is a warranty claim must be returned prepaid to an authorized OZ Lifting warranty depot along with proof of purchase.

**For more information please contact:**



P.O. Box 845, Winona, MN 55987

Phone (800) 749-1064

(507) 474-6250

Tech Support (507) 457-3346

Fax (507) 452-5217

sales@ozliftingproducts.com

**www.ozliftingproducts.com**

# Important Information and Precautions

This manual contains general instructions dealing with the normal installation, operation and maintenance of the products described herein.

This product should not be installed, operated, or maintained by any person who has not read all the contents of these instructions. Failure to read and comply with these instructions, warnings, or limitations noted might result in bodily injury, death, or property damage. Contact the distributor for further explanation if information is not fully understood.

It is the responsibility of the owner/user to install, test, maintain, and operate these products in accordance with OSHA regulations, other federal, state, and local regulations, and ANSI standards including:

- ANSI/ASME B30.21- Manually Lever Operated Hoists
- Other applicable volumes within ANSI/ASME B30

Only trained and qualified personnel shall operate and maintain this equipment.

## Maintain Records

Schedule and maintain records of regular inspection and maintenance of the product in compliance with ANSI standards.

Record your hoists Serial Number on the front cover of this manual to allow for easier referencing.

## Precautions

Do not use OZ Lifting products in conjunction with other equipment unless the system designer, manufacturer, installer, or user has put the necessary safety devices in place.

Modifications to upgrade, re-rate, or alter these products should only be authorized by the original manufacturer.

Hoists should be used for lifting loads only within their load ratings.

## These Lever Hoist meet or exceed the following standards:

**CE**  
**AS1418.2**  
**ANSI B30.21**  
**ANSI B30.16**



# Warnings

Failure to read and comply with the following warnings may result in a hazardous situation that could lead to death, serious injury, or property damage.

- Do Not operate the hoist with anything other than manual hand power.
- Do Not use lever hoist with extension on lever handle.
- Do Not operate if hook latch is missing or not functioning properly.
- Do Not lift more than the rated load.
- Do Not operate the product when it is restricted from forming a straight line with the direction of loading.
- Do Not operate with twisted, kinked, or damaged chain.
- Do Not operate if chain is not seated in sheaves or sprockets.
- Do Not wrap chain around load or use chain as a sling.
- Do Not operate until load chain is seated correctly in the load sheave.
- Do Not operate unless load is properly applied to the saddle or bowl of the hook.
- Do Not operate if load is applied to the tip of the hook or if hook is capsized.
- Do Not lift people.
- Do Not lift loads over people.
- Do Not operate beyond load chain's travel limits.
- Do Not operate with side pulling or side loading of load to hoist.
- Do Not operate a damaged or malfunctioning product.
- Do Not remove, deface, or obscure warning labels.
- Do Not leave a suspended load unattended, unless specific precautions are instituted.
- Do Not lengthen chain or repair damaged load chain by welding.
- Do Not use chain as an electrical or welding ground.
- Do Not operate until personnel are warned of approaching loads and are cleared from the area.



# Technical Information

(0.75, 1.5, 3, 6, and 9 tons)

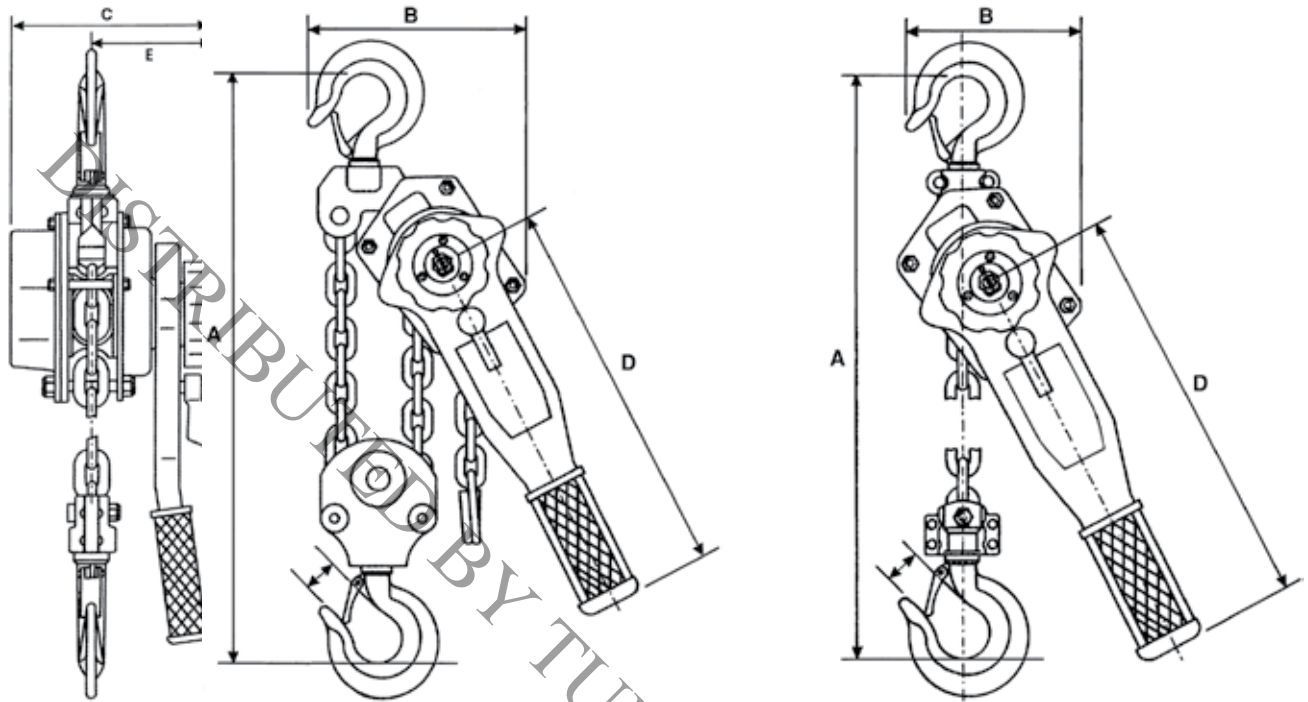

## Specification

Product Code	OZ075LHOP	OZ150LHOP	OZ300LHOP	OZ600LHOP	OZ900LHOP	
Safe Working Lift (tons)	0.75 (t)	1.5 (t)	3 (t)	6 (t)	9 (t)	
Headroom (in)	12.79 (in)	14.96 (in)	18.90 (in)	24.41 (in)	27.56 (in)	
Effort on lever to lift full load (lbs)	30.86 (lbs)	48.50 (lbs)	70.55 (lbs)	74.96 (lbs)	79.37 (lbs)	
Number of Load Chain Falls	1	1	1	2	3	
Diameter of Load Chain (mm)	6 (mm)	8 (mm)	10 (mm)	10 (mm)	10 (mm)	
Length of Lever Handle (in)	11.02 (in)	16.14 (in)	16.14 (in)	16.14 (in)	16.14 (in)	
Dimensional Information (in)	A	12.79 (in)	14.96 (in)	18.89 (in)	24.40 (in)	27.55 (in)
	B	5.35 (in)	6.29 (in)	7.08 (in)	9.25 (in)	12.44 (in)
	C	5.82 (in)	6.77 (in)	7.87 (in)	7.87 (in)	7.87 (in)
	D	11.02 (in)	16.14 (in)	16.14 (in)	16.14 (in)	16.14 (in)
	E	3.54 (in)	3.85 (in)	4.52 (in)	4.52 (in)	4.52 (in)
Hook-opening, upper & lower (in)	1.18 (in)	1.41 (in)	1.57 (in)	1.96 (in)	2.28 (in)	
Net Weight of Head Only (lbs)	13 (lbs)	22 (lbs)	33 (lbs)	51 (lbs)	67 (lbs)	

# Pre-Installation

Check for damage during shipment. Do not install or use a damaged product. Check and verify any structure or other equipment that will support the product has a rated load capacity equal to or greater than the rated load capacity of the product to be used.

## Before initial operation:

Read and comply with all instructions and warnings furnished with or attached to the product if applicable.

Check lubricant.

Check operation of the brake.

Where applicable, check that the chain is properly seated in sheaves and that the chain is not twisted, kinked, or damaged.

Correct all chain irregularities before use.

Make sure that all supporting structures are sufficient to support the hoist and the load.

Make sure the hoist is installed properly to a fixed point.

Check that all bolts, nuts, and cotter pins are securely in place.

## Before each shift, where applicable:

Inspect hooks for nicks, gouges, cracks, and signs of pulling apart or twisting.

Inspect hook latch for proper operation.

Check chain for kinks or twists.

Check operation of brake.

Replace warning label if missing or illegible.

## Before operating:

Be certain all personnel are clear of the load to be lifted and moved.

Make sure the load will clear stockpiles, machinery, or other obstructions when hoisting and traveling the load.

Make sure the hoist operation area allows enough room for lever operation, a clear zone for the operator and other personnel to stand, and allows the frame to swivel freely on the upper hook.





# Operation

## Warnings & Precautions

Hoist operators should read and fully comprehend this entire manual and all warnings on the hoist before beginning hoist operation. If this manual is not read and followed completely injuries may occur.

### Operator Requirements:

Read and fully comprehend this entire manual before hoist operation.

Must be trained in proper hoist operation and dealing with potential malfunctions.

Should not operate hoist while under influence of alcohol, medications, or drugs. Should not operate the hoist while tired or distracted.

Should not operate hoist if they have a history of seizures or other medical issues that may interfere with hoist operation.

Should have proper coordination and vision.

### Prior to Operation be sure:

Hoist is clean and properly lubricated.

Hoist is in proper working condition and maintenance records are up to date.

Brake is functioning properly.

Area of operation is clear of flammable materials.

### During Hoist Operation:

Maintain secure footing to prevent slipping and injury while operating.

Confirm that hoist unit is attached securely to a support before operation.

Verify hook latches are not supporting any of the load.

Do not hold the chain during hoist operation.

Slowly take up the load, verifying it is well supported and balanced before proceeding.

## Lever Hoist Operation

**Free Chain Operation-** Allows the unloaded hook to be moved to the desired position by hand in order to attach the load.

1. Place the selector to the Neutral position.
2. Pull the load chain to the desired position to attach the load.
3. To disengage the free chain operation, move the directional lever to the (up) or (down) position.
4. Pull the unit in both directions to assure it is out of free chain mode.

### Attaching the Load

1. If there are no twists in the chain proceed on to attach the lower hook to the load.
2. Do not use the chain to wrap around the load.
3. The load should be seated in the bowl of the hook and should not bear against the tip of the hook or latch.
4. The hook latch should be tightly closed against the hook tip
5. Assure that the upper and lower hooks form a straight line and frame is able to swivel.

## Lifting the Load

1. Place selector in the load (Up) position.
2. In this position the brake is engaged as lever stops in order to support the load.
3. Manually ratchet the lever in a clockwise rotation to lift the load.
4. Begin slowly in order to verify load is correctly seated and hoist is functioning properly.

## Pre-load Requirements

WLL 3/4 ton.	77 lbs.
WLL 1 1/2 ton.	84 lbs.
WLL 3 ton.	110 lbs.
WLL 6 ton.	121 lbs.
WLL 9 ton.	172 lbs.

## Lowering the Load

1. Place the selector in the unload (Down) position.
2. In this position the brake is engaged as lever stops in order to support the load.
3. Manually ratchet the lever in a clockwise rotation to lower the load.

## Locked Brake

If brake becomes locked during operation turn the lever to the unload (Down) position and pull sharply on the lever to unlock it.



## Overload Protection

Overload protection comes standard on all OZ Lifting hoists and is factory calibrated. The overload protection is integral with the hoist and prevents the operator from overloading the hoist. When activated, the overload will not allow hoist operation.

### Activation of overload protection:

- While lifting- Load should be lowered
- While pulling- Load should be released
- Indicates that a larger capacity hoist should be selected, or the lifting specialist should be consulted for another means of operation.

# Inspection

In order to maintain quality operation of the product, a regular inspection schedule should be set up by each operator. All inspections should be reported and maintained in a dated record log. These records should be available to all personnel involved with the product, and should be made available to OZ Lifting Products when a warranty issue is in question.

## Definitions

The following definitions are from the ANSI/ASME B03.21 and will be used in the inspections procedure that follows.

**Designated Person-** a person who is selected or assigned as being competent to perform specific duties to which they are assigned.

**Qualified Person-** a person that by possession of a recognized degree or certificate of professional standing, or through extensive knowledge, training, and experience, has successfully demonstrated they are able to resolve problems relating to the subject matter and work.

**Normal Service-** service that involves operation with randomly distributed loads within the rated load limit, or uniform loads less than 65% of rated load for not more than 15% of the time.

**Heavy Service-** service that involves operation within the rated load limit that exceeds normal service.

**Severe Service-** service that involves normal or heavy service with abnormal operating conditions.

## Inspection Classifications

Initial inspection should be done on all new, modified, and repaired products in accordance with Table 1. Thereafter, items to be inspected are indicated in Table 1 by F (Frequent) or P (Periodic). For hoists exposed to more severe environmental conditions inspections should be more frequent.

### Frequent Inspections

The operator or other designated person performs frequent inspections by doing a visual examination and by listening for unusual sounds while product is operating. Frequent inspections are usually performed on the following schedule:

**Normal Service-** Monthly inspections

**Heavy Service-** Weekly to monthly inspections

**Severe Service-** Daily or before each use to weekly inspections

### Periodic Inspections

A designated person performs periodic inspections, which are more detailed inspections, by doing visual examinations of external and internal conditions. These inspections are done on the following schedule:

**Normal Service-** Yearly inspection

**Heavy Service-** Semi-annually inspections

**Severe Service-** Quarterly inspections

## Exception

Brakes require more than audible and visual inspection. Check daily by operating the product with and without a load, stopping at various positions to ensure safe operation.

## TABLE 1 - INSPECTION CHART

In chart, **F** indicates Frequent Inspection, **P** indicates Periodic Inspection

LOCATION		CHECK FOR	F	P
Braking mechanism		Slipping under load	•	
		Hard to release	•	
Brake parts:	Brake Discs	Glazing		•
		Oil contamination		•
	Pawl: Ratchet	Excessive wear		•
	Pawl: Spring	Corrosion: stretch		•
Hook		Chemical damage	•	
		Operation	•	
		Deformation	•	
		Cracks (dye penetrant, magnetic particle, or other suitable detection method)		•
Hook retaining members Not tight or secure (Pins, Bolts, Nuts)		Not tight, secure or damaged		•
Hook Latch		Damaged; does not close	•	
Suspension Members (Sheaves, Hand-wheels, Chain attachments, Suspension bolts or pins)		Excessive wear		•
		Cracks	•	•
Gears		Distortion		•
		Broken or worn teeth		•
		Cracks		•
		Inadequate lubrication		•
Load Block: Suspension housing		Distortion	•	•
		Crack	•	•
Trolley: Supporting structure		Possible inability to continue supporting loads or damaged		•
Bolts, Nuts, Rivets		Not tight or secure		•
WARNING Labels		Removed or illegible	•	
Hoist Lever		Bent, cracked	•	
Proper operation		Unusual sounds	•	

Any deficiency found in the above inspection chart should be corrected before the hoist is put back into service.

**Note: Following disassembly of the hoist during inspection, a load test is required by ANSI/ASME B30.21 and should be done before the product is put back into operation.**

## Brake Disc Replacement Limits

Capacity	Load Chain	D (mm)	d (mm)	tn (mm)	tv (mm)
0.75 t	1	65.5	38.5	3.2	2.7
1.5 t	1	74	41.5	3.2	2.7
3 t	1	85	45.5	3	2.5
6 t	2	85	45.5	3	2.5
9 t	3	85	45.5	3	2.5

### N Series

Capacity	Load Chain	D (mm)	d (mm)	tn (mm)	tv (mm)
0.75 t	1	54	34	3.5	3
1.5 t	1	65	40.3	3.5	3
3 t	1	65	40.3	3.5	3
6 t	2	65	40.3	3.5	3
9 t	3	65	40.3	3.5	3

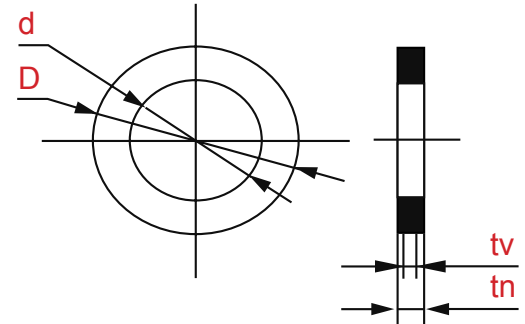

d = Inner Dia.  
D = Out Dia.  
tn = Normal measurement  
tv = Replacement limit

## Hook Inspection

### Warnings:

The OZ hoist with overload protection when used in accordance with safe operating procedures should greatly reduce the chance of a hook opening up.

1. Any OZ hook that requires replacement because of excessive bends, twists, or throat opening indicates abuse or overloading of the product. Therefore, other load-supporting components of the product should be inspected for possible damage when such conditions are found.
2. Never repair hooks by welding or reshaping. Heat applied to the hook will alter the original heat treatment of the hook material and reduce the strength of the hook.
3. Never weld handles or other attachments to the hook.

### Hook Inspection Procedure

Where applicable, inspect hooks and measure throat opening at least once a month. Between regular inspections daily inspections of the hooks should be done. Check for the following:

- Deformation, distortion, twisting, damage
- Missing, bent, or damaged hook latches
- Chemical damage, deformation, or cracks
- Greater than a 10-degree twist from the plane of unbent hook
- Excessive opening or seat wear

### Hook Latch

Hook latch inspection should include the following:  
Replace hooks that are opened to an extent that the latch does not engage the tip.

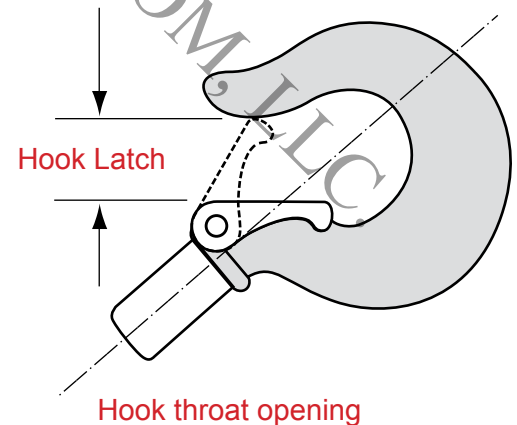

Latch should have enough spring pressure to keep it tight against the tip of the hook and allow it to spring back to the tip when released

Use the following chart to determine when the hook must be replaced. Replacement of the hook is necessary if any of the previous page problems are found or the maximum dimensions on the charts that follow are reached.

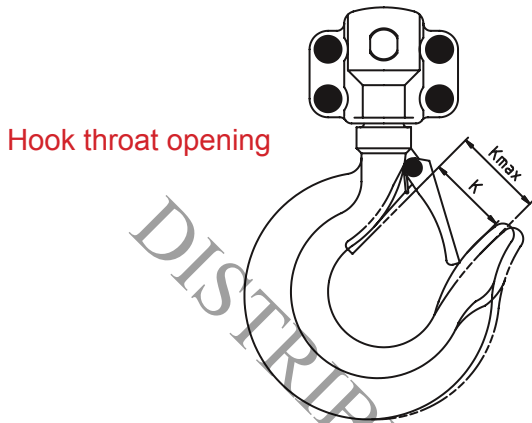

Size	Standard K (mm)	Max K (mm)
0.75 ton	26	28.5
1.5 ton	32.5	35.5
3 ton	37	40.5
6 ton	46	51
9 ton	50	58

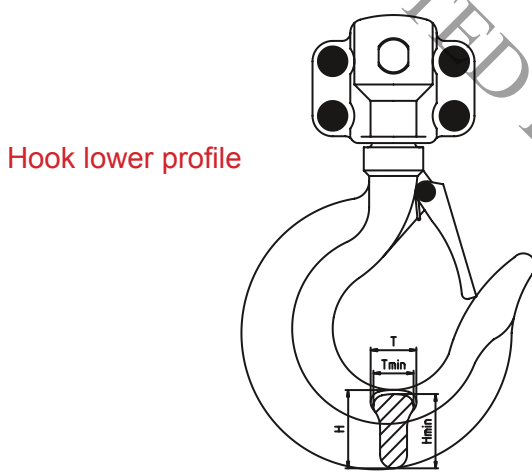

Size	Standard H (mm)	Min H (mm)	Standard T (mm)	Min T (mm)
.75 ton	21.5	19.3	13	11.7
1.5 ton	28.8	25.9	17	15.3
3 ton	43.9	39.5	25	22.5
6 ton	52.5	47	32	28.8
9 ton	60.5	54.5	40	36

## Chain Inspection

Inspect chain before each use. Between regular inspections visually check on a daily basis the following:

- Clean chain before inspection using a non-caustic/non-acid solvent
- Lubrication of the chain may be necessary if it binds up or is noisy
- Chain feeds smoothly into and from the hoist and does not emit cracking noise when hoisting a load
- Visually examine link by link for any nicks, gouges, weld splatter, corrosion, or distorted links pay close attention to chain's contact points, which may show excessive wear.
- Test hoist with load and observe operation of chain over load sheaves.

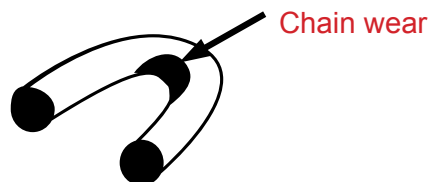

## Chain Warnings:

**Caution:** It must be recognized that certain factors in the usage of chain and attachments can be abusive and lessen the load that the chain or attachments can withstand. Some examples are twisting of the chain, disfigurement, deterioration by straining, usage, weathering and corrosion, rapid application of load or jerking applying excessive loads, and sharp corners cutting action.

Due to the crushing effect Grab Hooks have upon chain, the design factor of all assemblies must be reduced by 20% for Grab Hook applications.

Use the following chart to determine when the chain must be replaced. Replacement of the entire chain is necessary if any of the previous page problems are found or the maximum dimensions on the charts that follow are reached.

### Load Chain - One link length

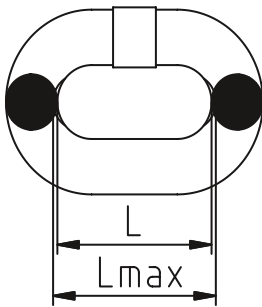

Dia	Standard L (mm)	Max L (mm)
4mm	12	12.6
5mm	15	15.8
6mm	18	18.9
8mm	24	25.2
10mm	30	31.5

### Load Chain - Diameter

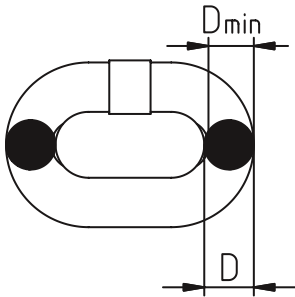

Dia	Standard D (mm)	Min D (mm)
4mm	4	3.6
5mm	5	4.5
6mm	6	5.4
8mm	8	7.2
10mm	10	9

### Load Chain - Five link length

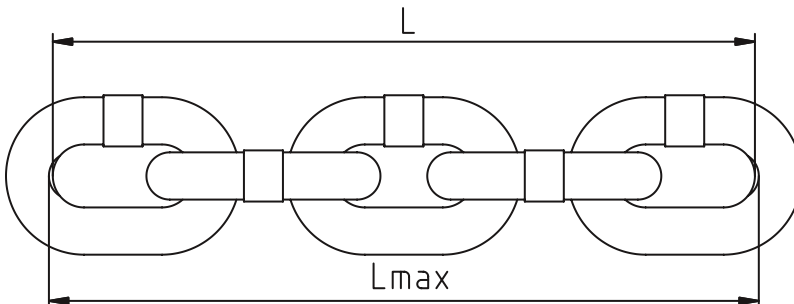

Dia	Standard L (mm)	Max L (mm)
4mm	60	61.8
5mm	75	77.5
6mm	90	92.7
8mm	120	123.6
10mm	150	154.5

# Maintenance

\*Visit [www.ozliftingproducts.com](http://www.ozliftingproducts.com) to view an Animated Maintenance Breakdown.

## Lubrication

Proper lubrication with machine oil is necessary to increase the life of the chain. Lubrication should be done based on usage and on a regular basis. It may be necessary on a weekly basis for heavy use or monthly if used less often.

- Clean the chain with an acid free cleaning solution to remove debris.
- Apply oil to chain focusing on bearing surfaces such as interlink areas.
- Do not apply oil to braking surfaces.
- Gears and shafts run on sealed bearings and do not require lubrication.

## Disassembly to Replace Load Sheave or Stripper

1. Remove the chain
2. Remove the lock nut (35), screw (39), lock washer (38), hand wheel (27), lever handle (22), overload/brake cover assembly (20), female thread grip (19), friction disc (17), ratchet disc (18), free spring (16), and disc hub (15).
3. From the gear side remove the gear case assembly (1), disk gear assembly (2), and drive shaft (3). Then remove the snap ring (47), splined gear (4), and gear side plate assembly (5). Slide the load sheave out of the gear side plate. Now the stripper can also be removed (10).

## Assembly

Before reassembly check each part for damage, corrosion, or excessive wear. Replace parts as necessary. Re-assemble the hoist in reverse order to the disassembly steps listed above. Once assembled the chain can be installed and before use the unit should be tested for proper function.

## Storage of Hoist

Store the hoist in a clean dry area.  
Maintain proper lubrication of the hoist while it is being stored.  
If the hoist is malfunctioning clearly mark it before placing it in storage.

## Outdoor Hoist Usage

Store hoist indoors when not in use.  
Frequently inspect the hoist for signs of corrosion due to environmental factors.



# Spare Parts List

FIG. NUMBER	DESCRIPTION
1	GEAR CASE ASSY
2	DISC GEAR ASSY
3	DRIVE SHAFT
4	SPLINED GEAR
5	GEARED SIDE PLATE ASSY
6	LOAD SHEAVE
7	GUIDE PLATE
10	STRIPPER
11	LEVER SIDE PLATE ASSY
15	DISC HUB
16	FREE SPRING
17	BRAKE DISC
18	RATCHED DISC
20	OVERLOAD/BRAKE COVER ASSY
22	LEVER HANDLE ASSY
23	CHANGE OVER PAWL
24	SPRING SEAT
25	CHANGE OVER SPRING
27	HANDWHEEL
28	LOAD CHAIN-PER FOOT
29	CHAIN RING
30	NAME PLATE
31	TOP HOOK ASSY
32	TOP HOOK SHAFT
33	BOTTOM HOOK ASSY
34	CHAIN PIN
35	HEX NUT/SAME AS #37
40	CASTLE NUT
41	SPLIT PIN
42	LOCK NUT
44	SCREW
45	LOCK WASHER/ALSO #36
46	RIVET
47	SNAP RING
61	HOOK SAFETY LATCH

# Spare Parts

(0.75 ton - 9 ton)

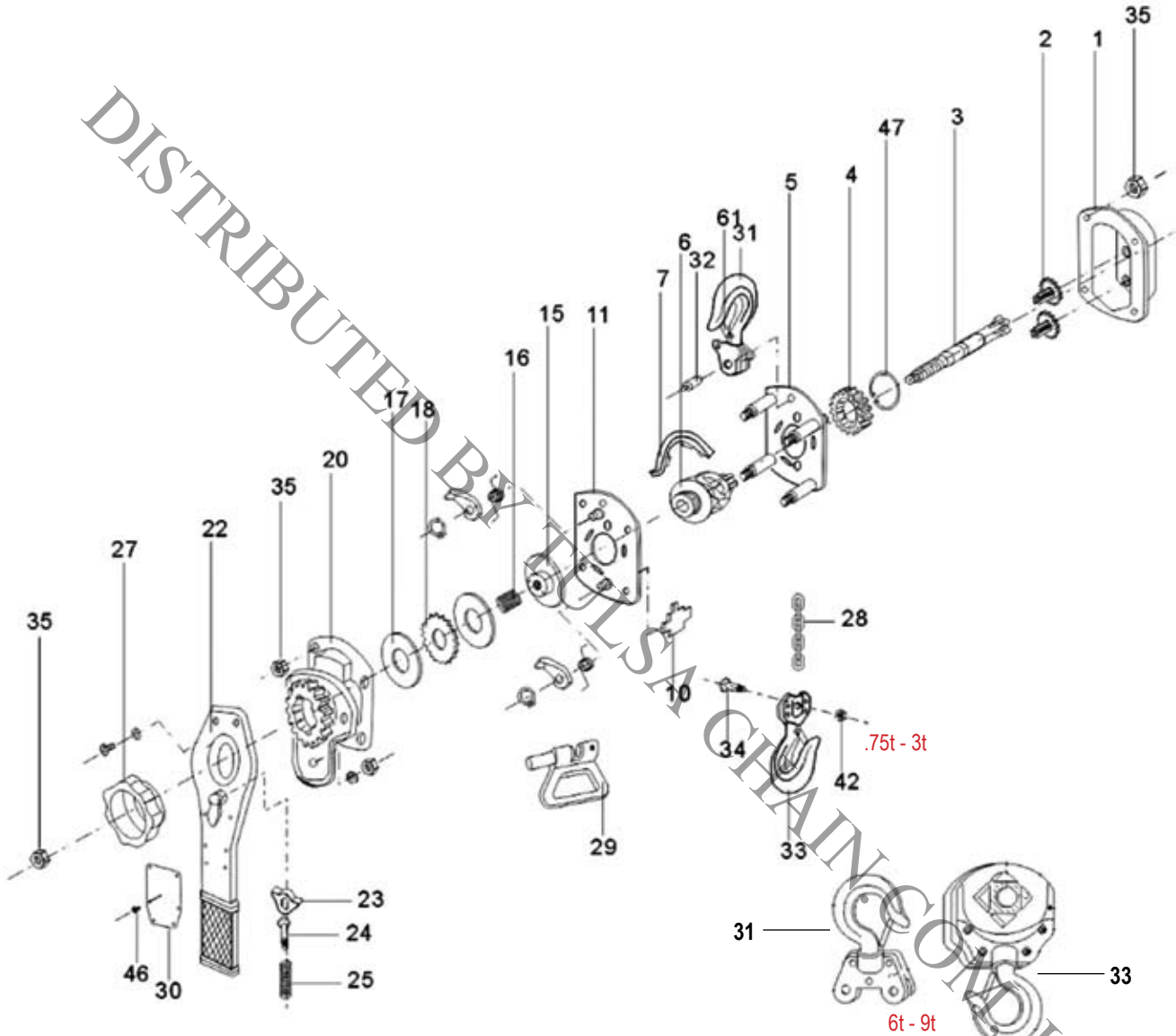

# Service Notes

DISTRIBUTED BY TULSA CHAIN.COM, LLC.

DISTRIBUTED BY TULSA CHAIN.COM



P.O. Box 845, Winona, MN 55987  
Phone (800) 749-1064  
(507) 474-6250  
Tech Support (507) 457-3346  
Fax (507) 452-5217  
sales@ozliftingproducts.com  
[www.ozliftingproducts.com](http://www.ozliftingproducts.com)